

gentle forms_

a quiet expression of comfort





gentle forms_

a quiet expression of comfort

divani | sofas

Coccola	02 - 13
Clizia	14 - 25
Duplo	26 - 39
Nido	40 - 47
Gala	48 - 57
Sorriso	58 - 69

poltrone | armchairs

Iside	72 - 75
Macaron	76 - 81
Morea	82 - 87

tavolini | coffee tables

Luna	88 - 83
Kiko	94 - 99



*Morbide forme lunari
si distendono nello spazio,
definendo un'atmosfera
sospesa e silenziosa.*

*Soft lunar shapes stretch
out into space, defining
a suspended and silent
atmosphere.*

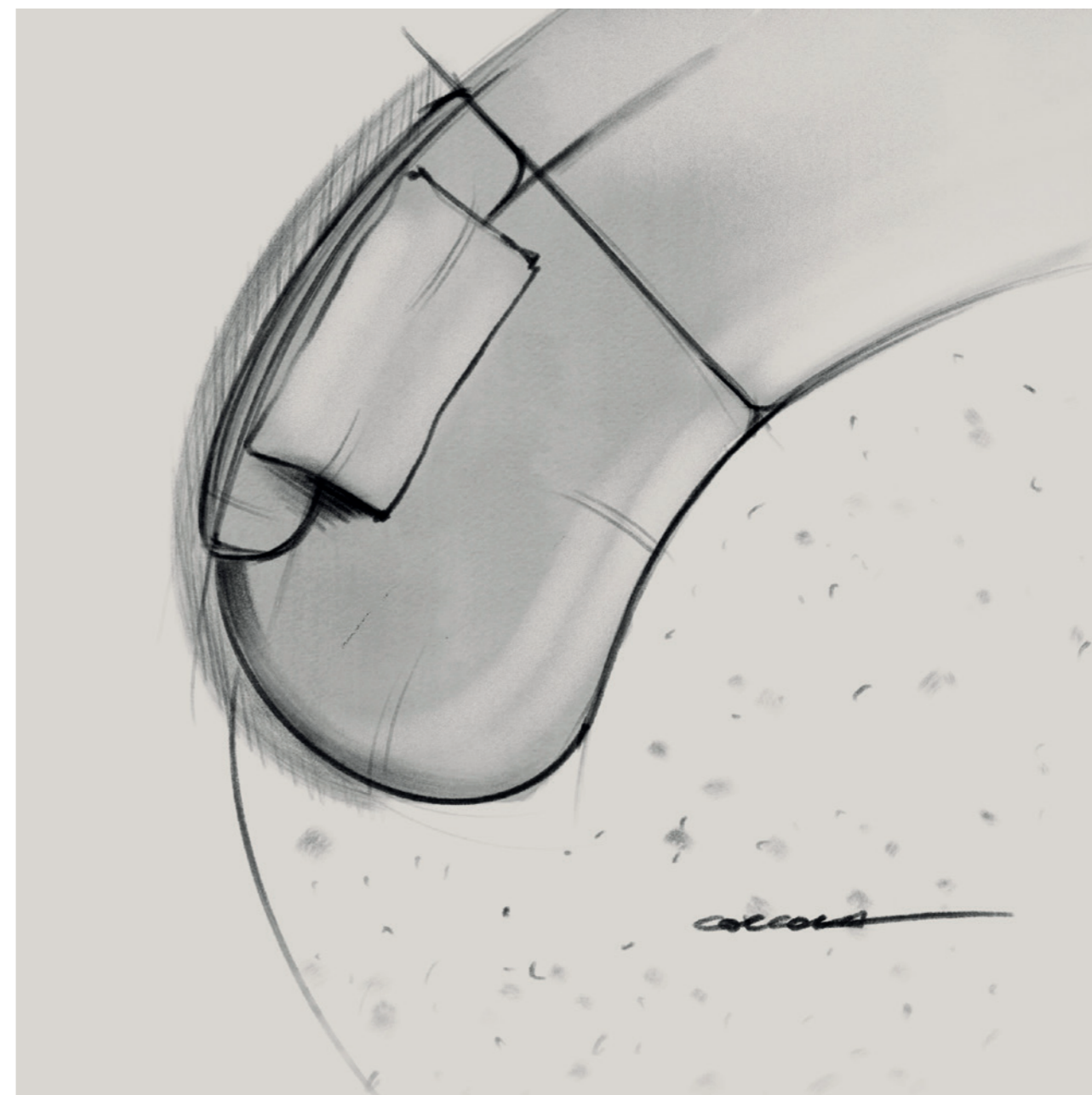

Coccola



Sistema di seduta dal design contemporaneo, caratterizzato da volumi generosi e proporzioni calibrate. Le imbottiture accoglienti e le linee fluide costruiscono un equilibrio pensato per il relax.

*Contemporary seating system characterized by bold volumes and balanced proportions.
Welcoming upholstery and fluid lines offer a perfect harmony tailored for relaxation.*





Divano modulare dal disegno organico, progettato per offrire massima libertà compositiva.
Il sistema si articola in modulo terminale, elemento centrale e terminale sagomato "a fagiolo",
per configurazioni armoniche e dinamiche.



*Modular sofa with organic design, engineered for maximum compositional flexibility.
The system features central and end units, a bean-shaped terminal unit to create harmonic
and dynamic configurations.*





Lo schienale traslante, elemento distintivo del progetto, consente di ampliare la profondità della seduta e modulare il comfort. Un movimento fluido accompagna il passaggio da una postura più composta a una dimensione di completo relax.

The shifting backrest, a signature feature of the design, allows for adjustable seat depth and customizable comfort. A smooth motion seamlessly transitions from an upright position to a state of relaxation.





*Una linea morbida
si sviluppa con naturalezza,
definendo un profilo
continuo ed essenziale.*

*A soft line develops naturally,
defining a continuous and
essential profile.*



Clizia



Divano dalle proporzioni equilibrate, caratterizzato da geometrie pulite e volumi pieni.
I braccioli leggermente arrotondati accompagnano la seduta dalla forma sottile e tondeggiante,
mentre la base rialzata su piedini discreti alleggerisce l'insieme, conferendo slancio e contemporaneità.

*A sofa of balanced proportions, featuring clean geometrics and full volumes.
The slightly rounded armrests complement the slim and curved seat, while the raised base on discreet feet,
lightens the overall silhouette, adding a touch of sleek contemporary flair.*









Gli schienali, regolabili in altezza, permettono di adattare il livello di supporto, offrendo un'esperienza d'uso versatile, dal relax alla conversazione.

Adjustable backrests let you tailor the support to your needs, ideal for lounging and conversation.





*Geometrie morbide
si susseguono con
ritmo misurato,
defnendo un'architettura
equilibrata e silenziosa.*

*Soft geometries follow
one another with a
measured rythm,
defning a balanced
architecture.*

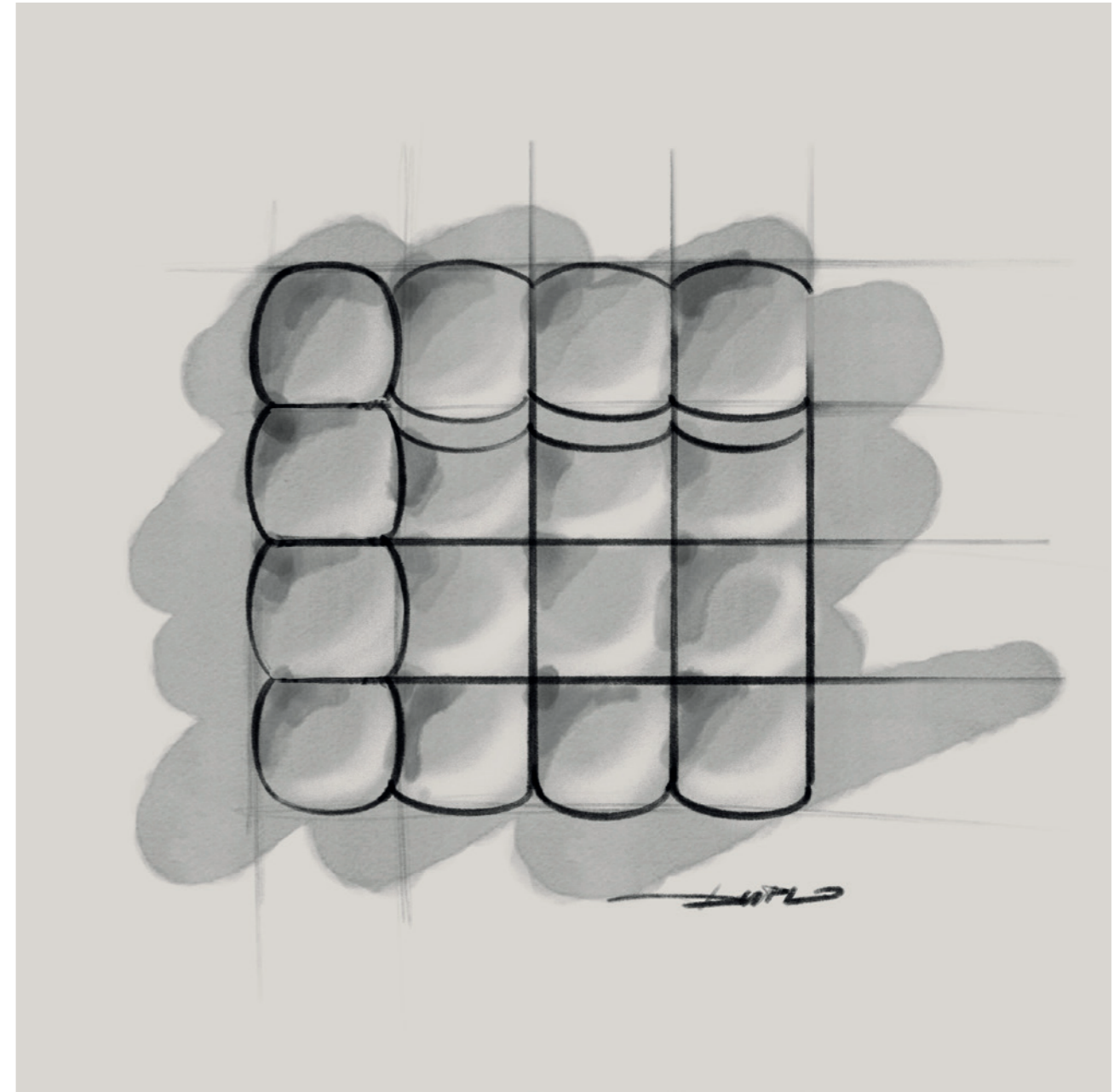

Duplo



Divano componibile dal carattere materico, definito da una struttura modulare e da un disegno tridimensionale che enfatizza comfort e accoglienza.

A modular sofa with a tactile character, defined by a versatile structure and a three-dimensional design that emphasizes comfort and coziness.







Lo schienale integra un sistema a doppio movimento che consente diverse inclinazioni, offrendo una regolazione evoluta e una risposta puntuale alle diverse posture.

The backrest features a dual-movement system for multiple tilt positions offering adjustability and tailored support for various sitting postures.



Duplo



Un divano dalle imbottiture profondamente scolpite, dove emergono i volumi tridimensionali morbidi e avvolgenti.

A sofa distinguished by its deeply sculpted padding, where soft, enveloping three-dimensional forms rise and flow.





Duplo è il protagonista al centro del tuo living, fulcro elegante che definisce lo spazio e ti accoglie in ogni momento di relax.

Duplo stands as the heart of your living room, an elegant centerpiece that shapes the space and embraces you in every moment of relaxation.



*Un elemento essenziale
attraversa il volume
con continuità,
definendo un'identità
riconoscibile.*

*A minimalist element
runs continuously
through the volume,
creating a signature
identity.*

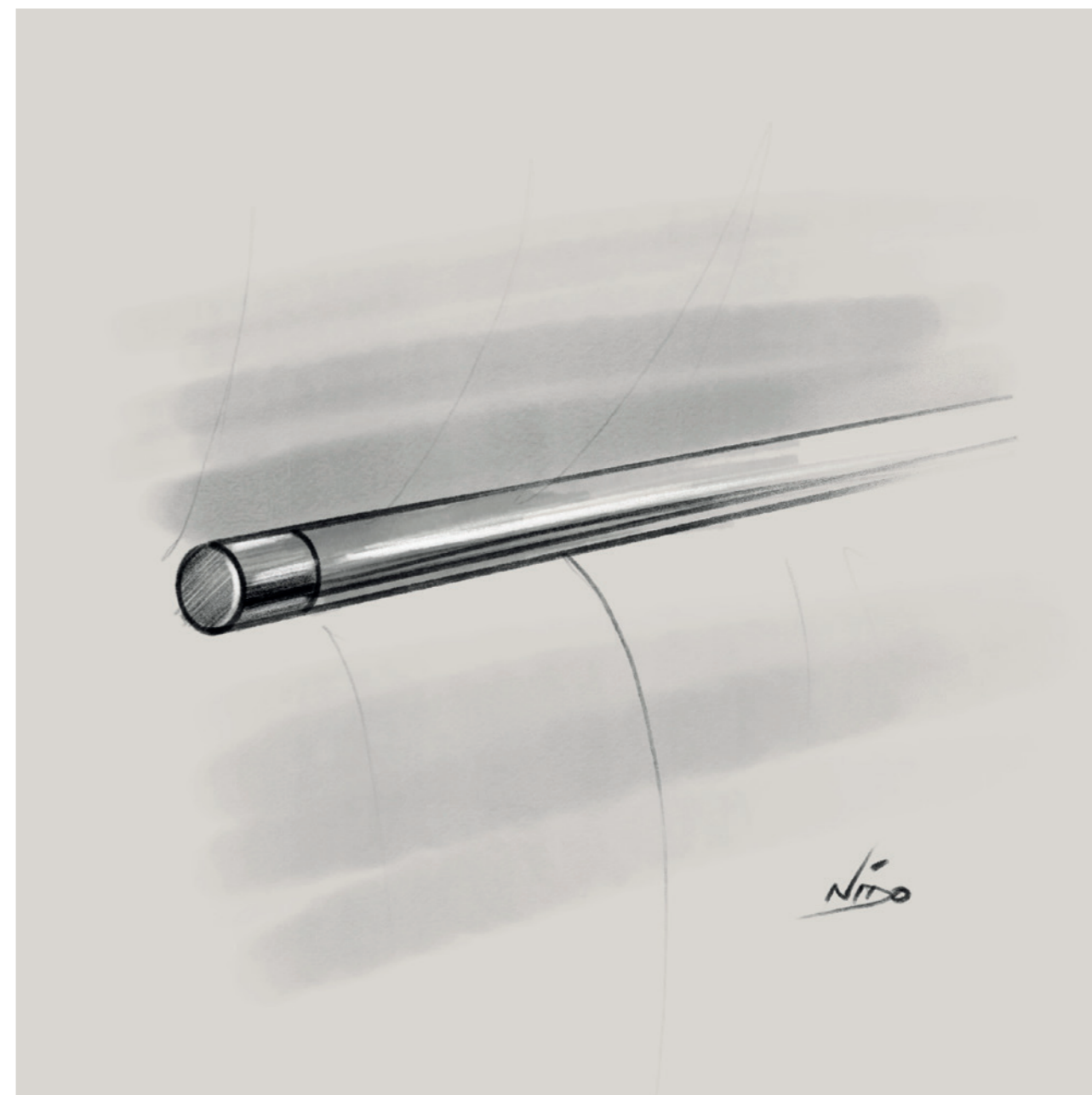

Nido



Divano componibile dal design contemporaneo, progettato per offrire libertà compositiva e comfort informale. I volumi ampi definiscono una seduta rilassata, completata da cuscini generosi.

Contemporary modul sofa designed for versatile layouts and laid-back comfort. Its bold volumes ensure a relaxed sit, complemented by generous cushioning







Elemento distintivo è il dettaglio di schienale e braccioli: una struttura in metallo rivestita in pelle percorre il profilo del divano, introducendo un accento materico sofisticato.

The defining feature lies in the detail of the backrest and armrests..A leather-covered metal structure runs along the sofa's profile, providing a sophisticated textural accent.



*Una linea sinuosa si solleva
e accompagna il gesto,
come un'onda che si tende
e si rilassa, dove la forma si
modella con naturale eleganza
e il dettaglio diventa
espressione.*

*A sinuous line rises and
accompanies the movement,
like a wave that stretches
and relaxes, where the form
is modeled with natural
elegance and the detail
becomes expression.*



Gala



Il modello componibile Gala: invitante alla vista, irresistibile ed irrinunciabile dopo aver sperimentato la soffici ta delle sue sedute a saponetta e degli avvolgenti schienali. Le parti imbottite nascondono infatti un'anima in piuma e poliuretano espanso, garanzia di un comfort impareggiabile.

The modular Gala model: inviting to the eye, irresistible and unmissable after experiencing the softness of its soapy seats and enveloping backrests. The padded parts conceal feather and polyurethane foam, a guarantee of unparalleled comfort.









Gala è l'espressione di cura sartoriale. Preziose sono infatti le finiture delle parti imbottite, i cui profili sono definiti da bandine in pelle e gli alamari in legno che abbiamo inserito come elementi decorativi e di raccordo tra la seduta e i braccioli.

Gala is an expression of sartorial care. The finishes of the upholstered parts, the profiles defined by leather bands, and the wooden frogs that we have inserted as decorative and connecting elements between the seat and the armrests.



*Una superficie morbida
si tende come un velo,
sospesa su segni essenziali
che la sorreggono, dove il peso
si dissolve in un equilibrio
leggero e continuo.*

*A soft surface
stretches like a veil,
suspended on essential lines
that support it,
where the weight dissolves
in a light and continuous
balance.*



Sorriso



Il divano modulare Sorriso è l'espressione alla sola vista di un mood accogliente e confortevole, la dimensione ideale per una rigenerante pausa relax. Pensato, con i suoi volumi ampi e vaporosi, per dominare lo spazio del living, questo modello può essere declinato in diverse configurazioni.

The Sorriso modular sofa, at the mere sight of it, with a cosy and comfortable mood, proves to be the ideal size while having a relaxing break. Thought with its ample and vaporous volumes, to dominate the living room, this model is offered in different configurations.







Il divano angolare si distingue per i dettagli sartoriali. Questi sono dati, oltre che dalla trapuntatura delle parti imbottite, anche dai particolari risvolti presenti nelle parti terminali di braccioli e schienali.

This sectional is distinguished by its sartorial details, quilted areas but also by the special flaps at the ends of the armrests and backrests.







*Volumi pieni si raccolgono
in una forma compatta,
addolciti da un gesto sottile
che si slancia con leggerezza,
come un segno delicato
che rompe la massa
e la rende viva.*

*Solid volumes gather into
compact shape, softened by a
slender movement that glides
upward, a delicate touch that
breaks the mass and make it
breath.*



Iside



Poltroncina girevole dalle dimensioni contenute, pensata per offrire comfort ed eleganza.
Braccioli e base, rivestiti in pelle, definiscono un profilo deciso e coerente.

A compact swivel chair crafted to offer both comfort and elegance. Upholstered arms and base define its strong cohesive profile.





*Forme arrotondate
si intrecciano come petali
che si aprono con naturalezza,
dando vita a un rifugio intimo,
dove la morbidezza
diventa esperienza.*

*Rounded shapes weave
together like petals unfolding
with ease, giving life to an
intimate sanctuary, where
softness becomes an
experience.*



Macaron



Un sistema di seduta dal design contemporaneo, caratterizzato da forme generose e avvolgenti e da imbottiture ampie che invitano al relax. Le linee morbide e fluide definiscono un'estetica elegante e accogliente, capace di valorizzare ogni ambiente con personalità.

A seating system with a contemporary design, characterized by generous, enveloping shapes and wide padding that invites relaxation. The soft, flowing lines appear to have an elegant and welcoming aesthetic, capable of enhancing any space with personality.





*Un tratto morbido
si chiude e si avvolge,
disegnando uno spazio raccolto,
dove la forma nasce dal gesto
e il comfort prende forma.*

*Soft contours wrap and enclose
creating an intimate space where
shape springs from a gesture
and comfort comes to life.*



Morea



Poltroncina girevole caratterizzata da un profilo curvo e armonioso.
Lo schienale accompagna la seduta con continuità, mentre il rivestimento è disponibile in tessuto,
pelle o nella combinazione dei due materiali.

A curved and harmonious swivel chair . Featuring a continuous backrest-to-seat design
available in fabric, leather or mix of both.





*Forme fluide
dialogano tra loro,
costruendo un equilibrio
calibrato tra leggerezza
e presenza.*

*Fluid shapes engage in
a dialogue, creating a
balanced harmony of
lightness and presence.*



Luna



Luna



Set di tavolini dalle geometrie organiche, progettati per composizioni libere.
I piani, morbidi e irregolari, si combinano con basi rivestite
in pelle, introducendo un contrasto materico discreto.

*A set of shaped side tables featuring organic geometries, crafted for versatile compositions.
The soft and irregular tops pair with leather upholstered bases,
creating a sophisticated play on materials.*



*Linee tese si incontrano
e si piegano generando
un nodo fluido
ed elegante.*

*Tense lines meet and
bend,
creating a fluid
and elegant knot.*

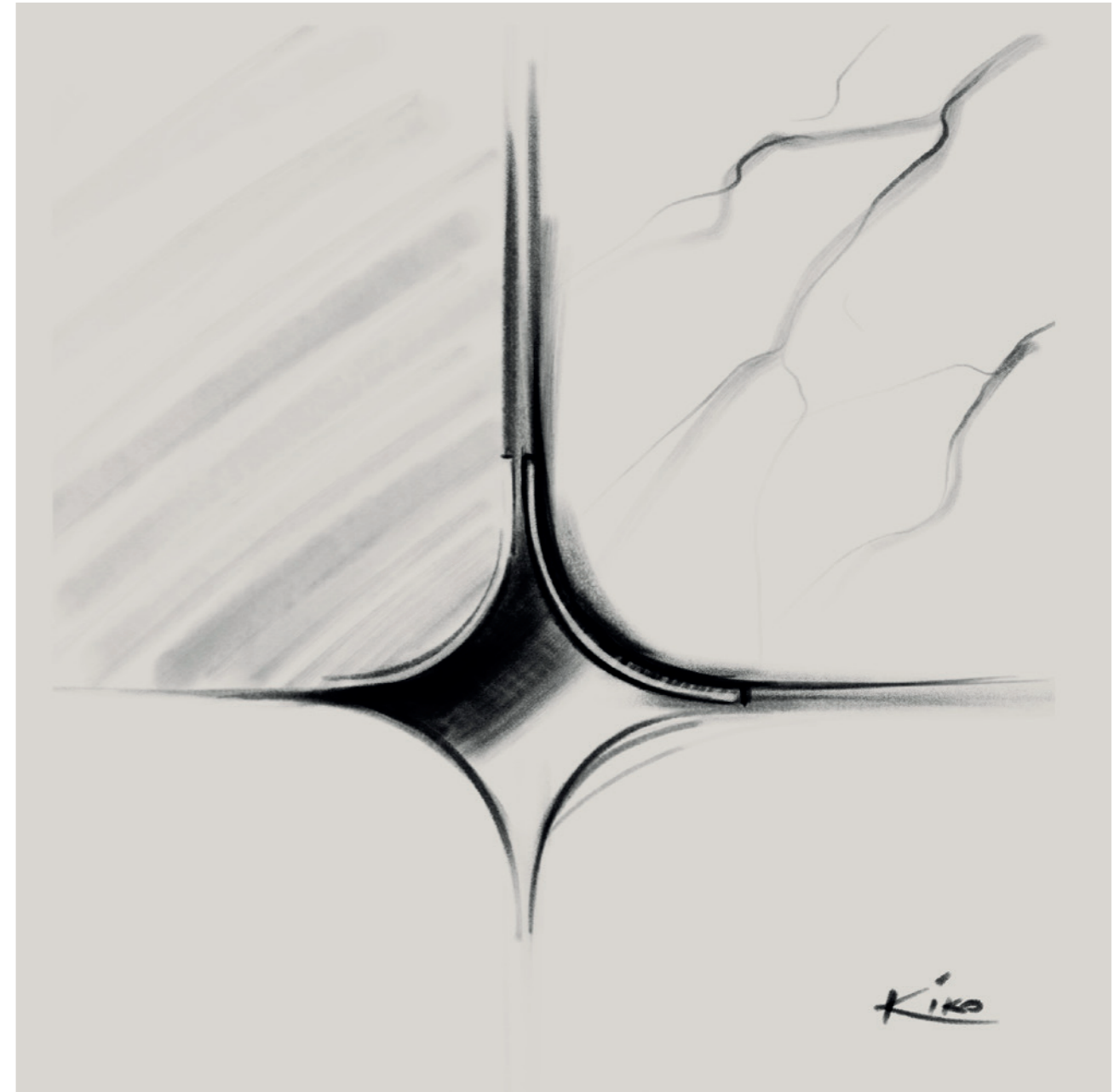

Kiko



Tavolini dalle proporzioni essenziali, caratterizzati da un rapporto armonico tra piano e struttura. Il top slanciato dialoga con basi curve in metallo, esprimendo una sintesi tra rigore e morbidezza.

*Coffee tables with essential proportions, with a harmonious balance between top and structure.
The slender top meet with curved metal bases, a mixture of synthesis and softness.*







Schede tecniche
Technical sheet

Divani | Sofas

Poltrone | Armchairs

Tavolini | Coffee tables

mod. **Clizia**

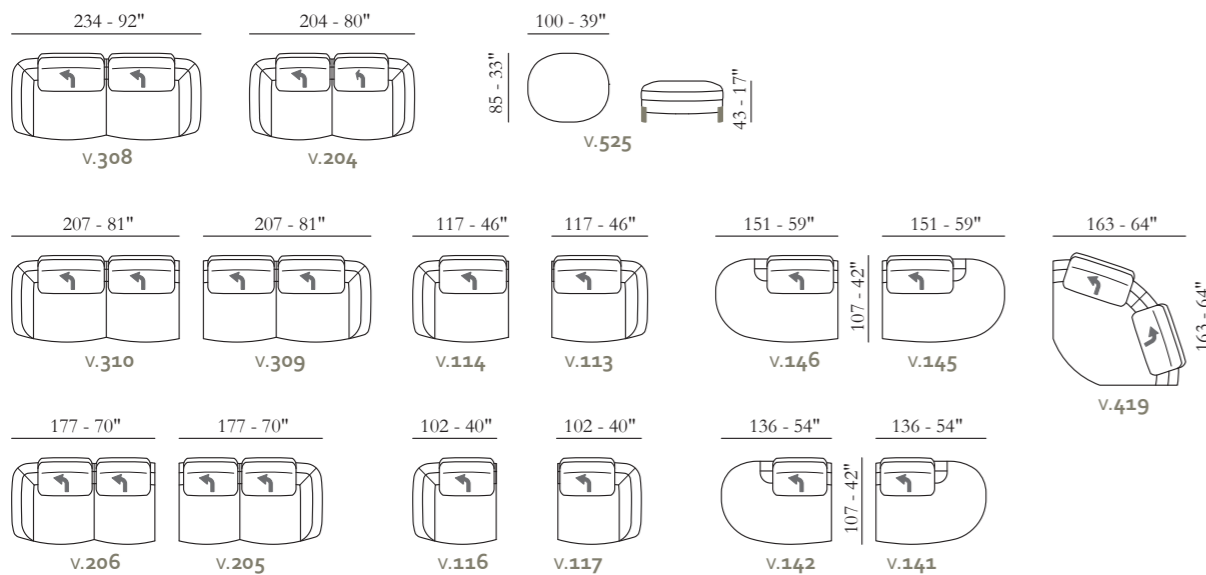
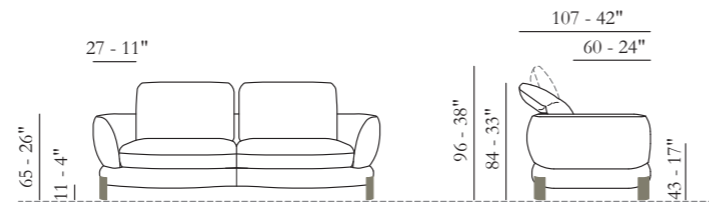

Esempi di componibilità - Sectionals examples - Exemples de compositions - Ejemplos de modularidad

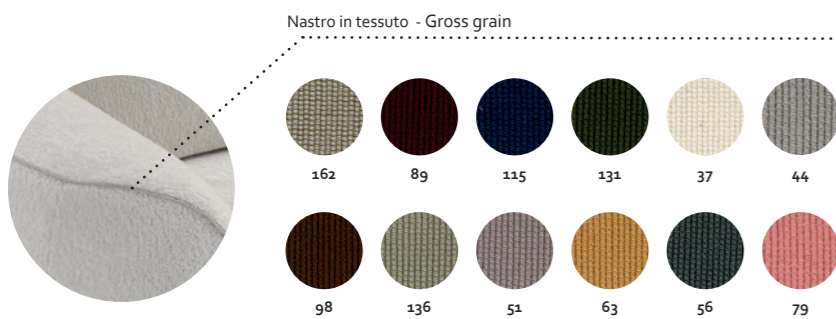
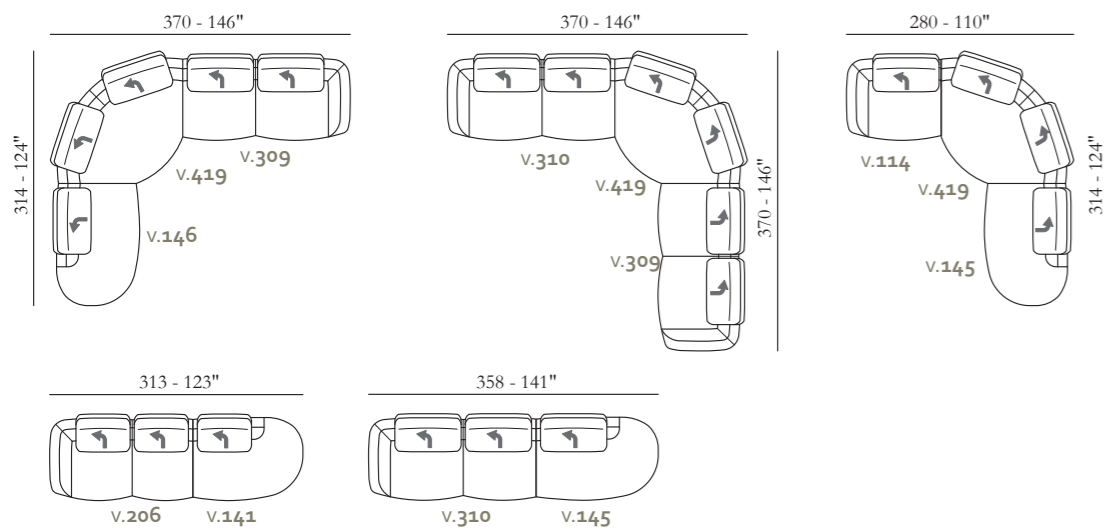

mod. **Coccola**

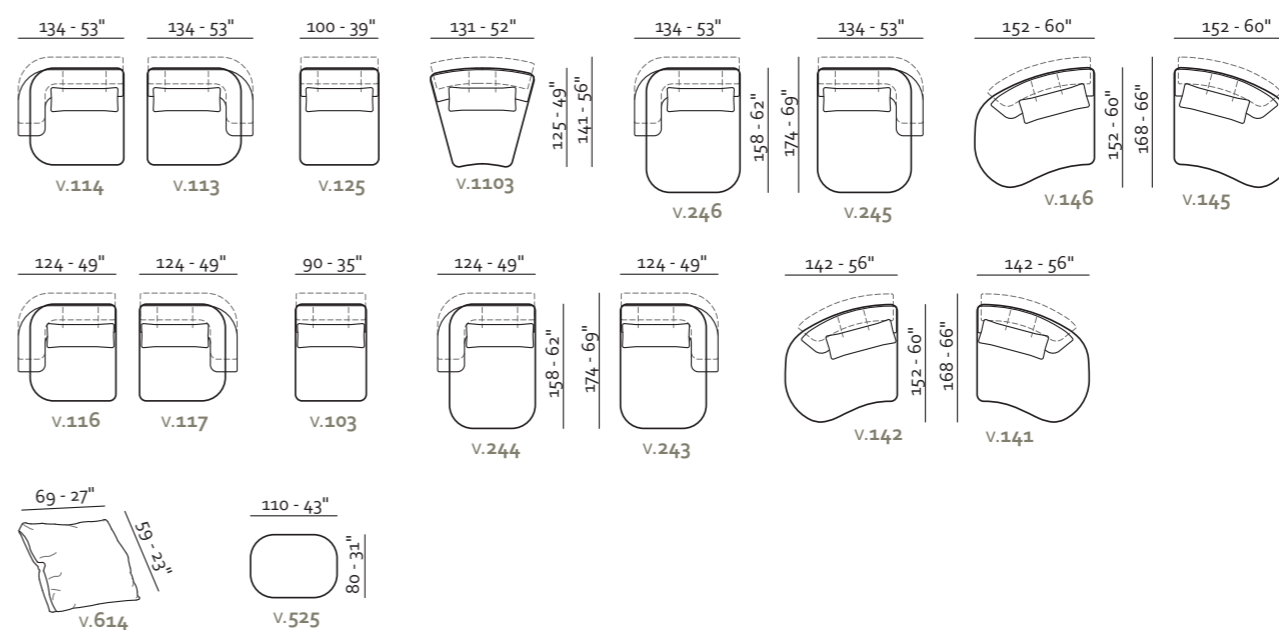
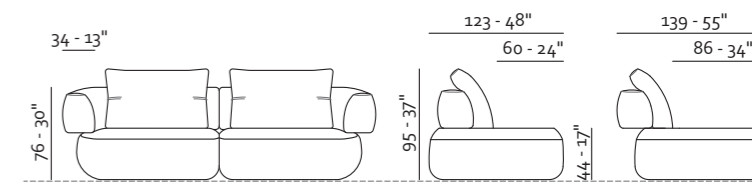

Esempi di componibilità - Sectionals examples - Exemples de compositions - Ejemplos de modularidad

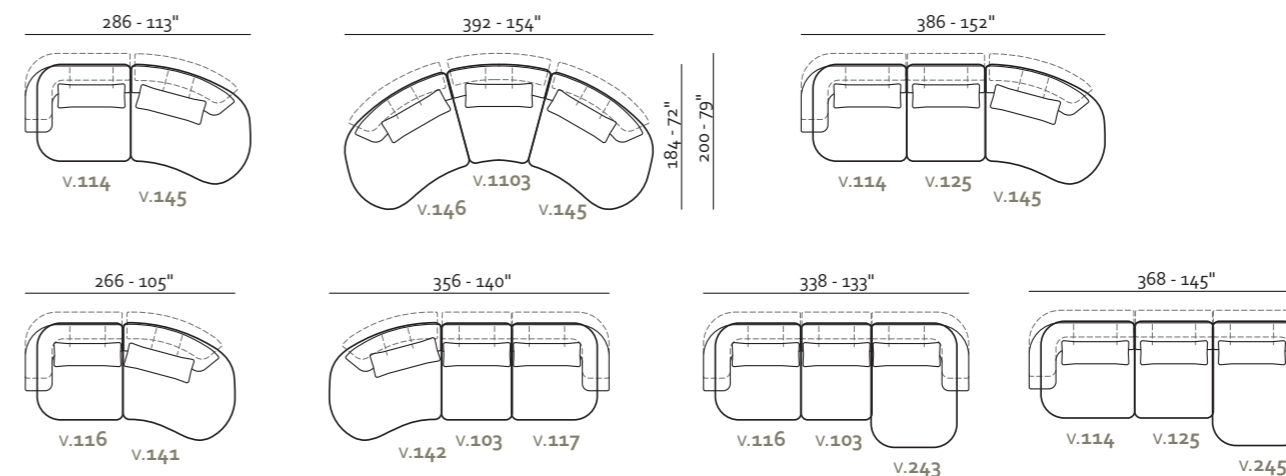

- Rivestimento Pelle / Tessuto
- Imbottitura BRACCIOLI / Poliuretano espanso SEDUTA / Poliuretano espanso SPALLIERA / Piuma
- Opzioni Nastro in tessuto
- Comfort Standard
- Piedi Metallo
- Struttura Telaio in legno

- Coverings Leather / Fabric
- Filling ARMS / Foam SEAT CUSHION / Foam BACK CUSHION / Feather
- Options Gros Grain
- Comfort Standard
- Legs Metal
- Structure Wooden frame

- Revêtement Cuir / Tissu
- Rembourrage ACCOUDOIRS / Mousse ASSISE / Mousse DOSSIER / Plumes
- Options Gros Grain
- Comfort Standard
- Pieds Metal
- Structure Structure en bois

- Revestimiento Piel / Tela
- Imbottitura APOYABRAZOS / Poliuretano expandido SENTADA / Poliuretano expandido RESPALDO / Piuma
- Opciones Gros Grain
- Comfort Estándar
- Pies Metal
- Struttura Estructura en madera

- Finitura piedi / Legs finishes Finition de pieds / Acabados de pies

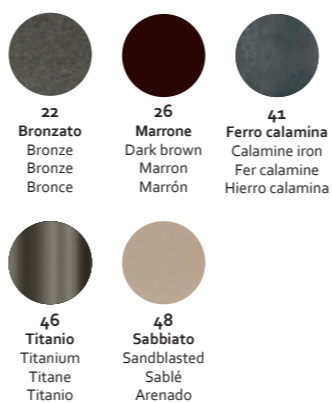

- Rivestimento Pelle / Tessuto
- Imbottitura BRACCIOLI / Poliuretano espanso SEDUTA / Poliuretano espanso SPALLIERA / Piuma
- Comfort Standard
- Piedi Plastica
- Struttura Telaio in legno

- Coverings Leather / Fabric
- Filling ARMS / Foam SEAT CUSHION / Foam BACK CUSHION / Feather
- Comfort Standard
- Legs Plastic
- Structure Wooden frame

- Revêtement Cuir / Tissu
- Rembourrage ACCOUDOIRS / Mousse ASSISE / Mousse DOSSIER / Plumes
- Comfort Standard
- Pieds Plastique
- Structure Structure en bois

- Revestimiento Piel / Tela
- Imbottitura APOYABRAZOS / Poliuretano expandido SENTADA / Poliuretano expandido RESPALDO / Piuma
- Comfort Estándar
- Pies Plástico
- Struttura Estructura en madera

mod. **Duplo**

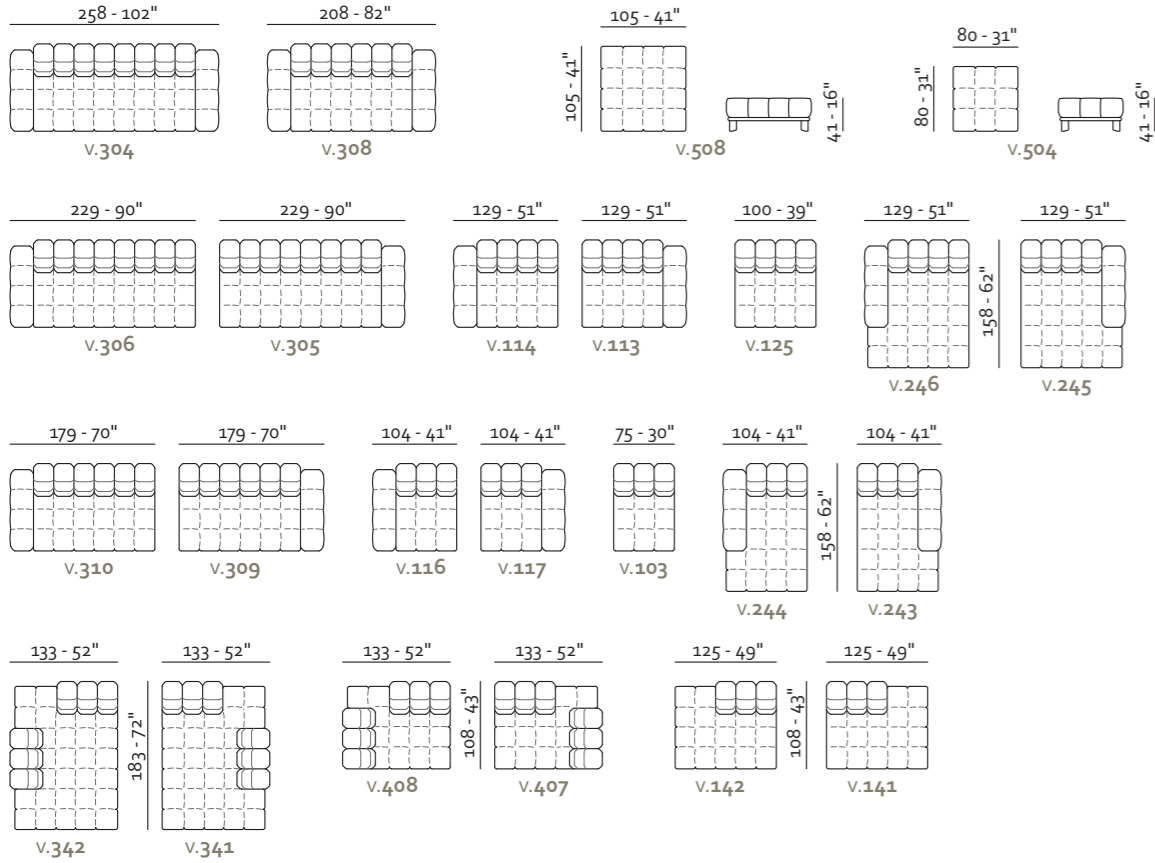
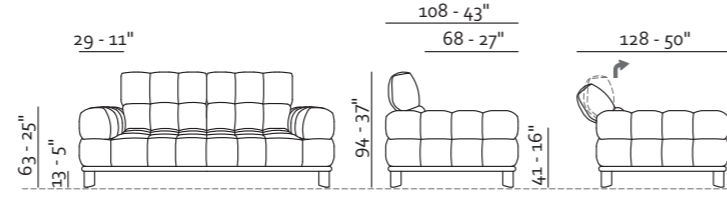

Esempi di componibilità - Sectionals examples - Exemples de compositions - Ejemplos de modularidad

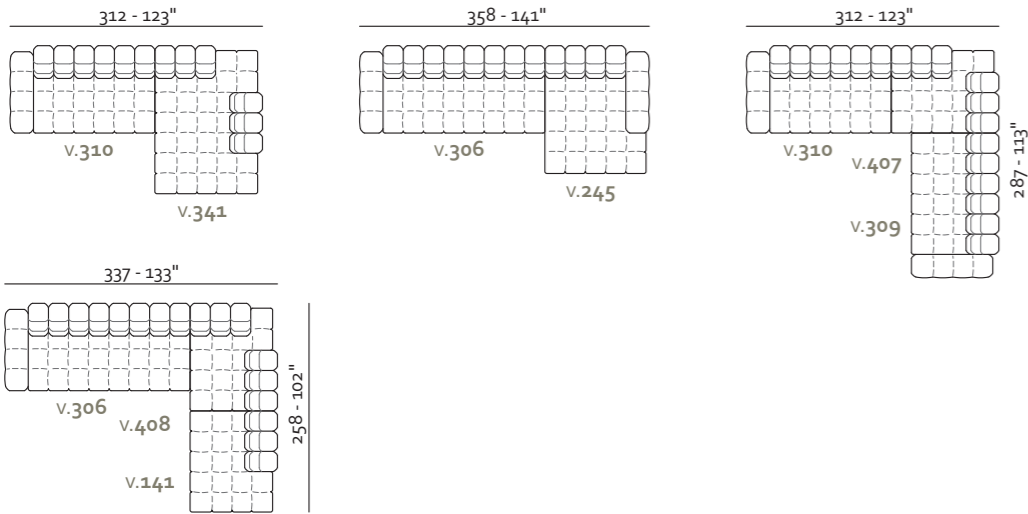

- Rivestimento
Pelle / Tessuto
- Imbottitura
BRACCIOLI / Poliuretano espanso
SEDUTA / Poliuretano espanso
SPALLIERA / Poliuretano espanso
- Comfort Standard
- Piedi Metallo
- Struttura Telaio in legno

- Coverings
Leather / Fabric
- Filling
ARMS / Foam
SEAT CUSHION / Foam
BACK CUSHION / Foam
- Comfort Standard
- Legs Metal
- Structure Wooden frame

- Revêtement
Cuir / Tissu
- Rembourrage
ACCOUDOIRS / Mousse
ASSISE / Mousse
DOSSIER / Mousse
- Comfort Standard
- Pieds Metal
- Structure Structure en bois

- Revestimiento
Piel / Tela
- Imbottitura
APOYABRAZOS / Poliuretano expandido
SENTADA / Poliuretano expandido
RESPALDO / Poliuretano expandido
- Comfort Estándar
- Pies Metal
- Struttura Estructura en madera

- Finitura piedi / Legs finishes
Finition de pieds / Acabados de pies

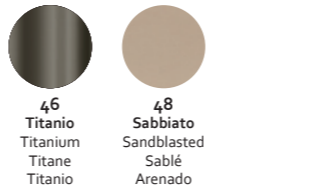
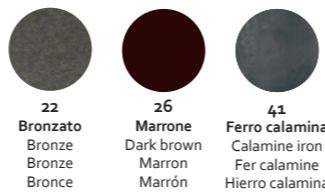

mod. **Gala**

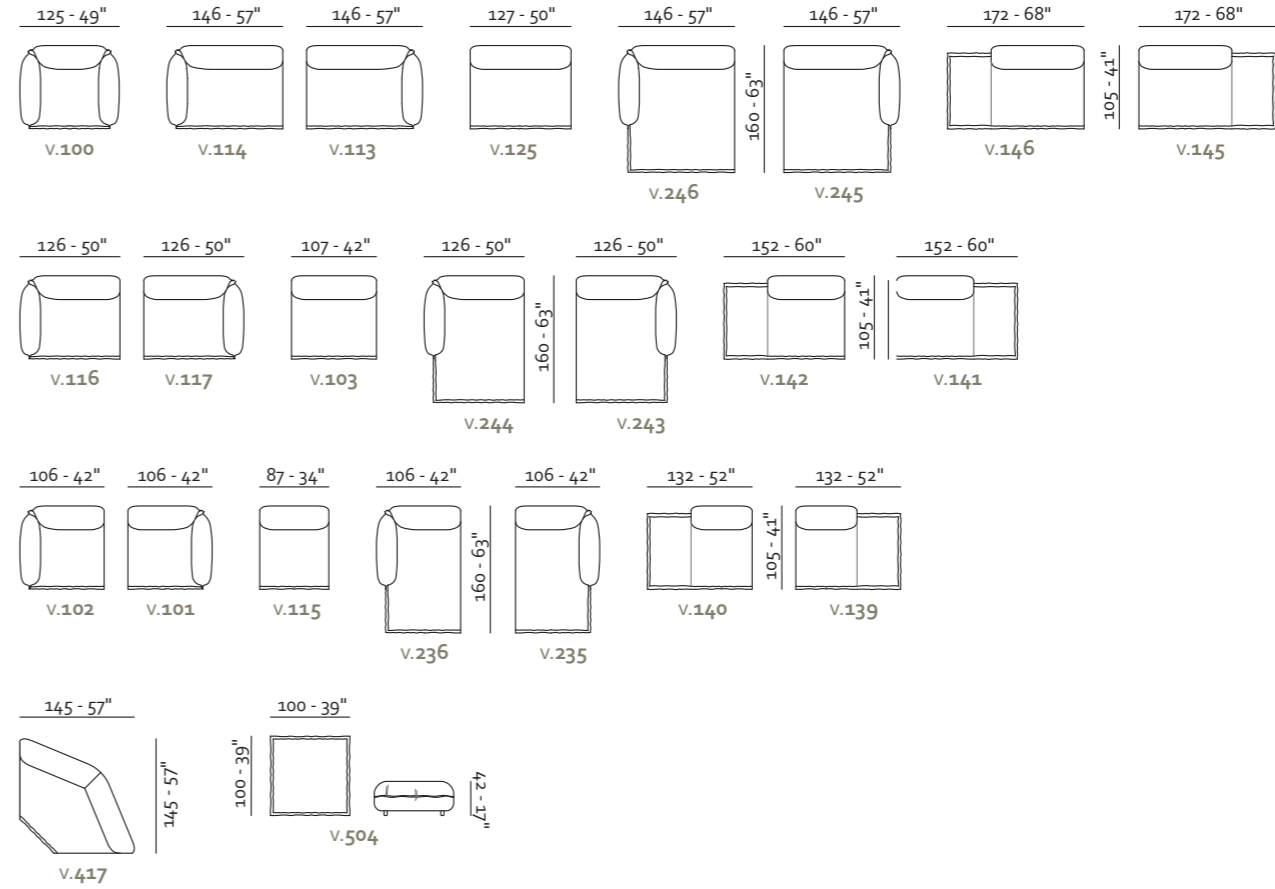
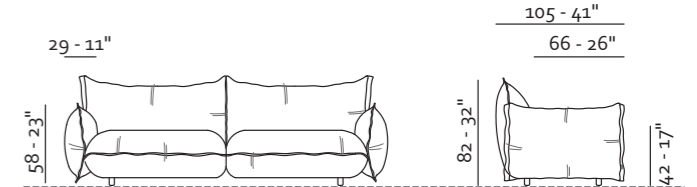

Esempi di componibilità - Sectionals examples - Exemples de compositions - Ejemplos de modularidad

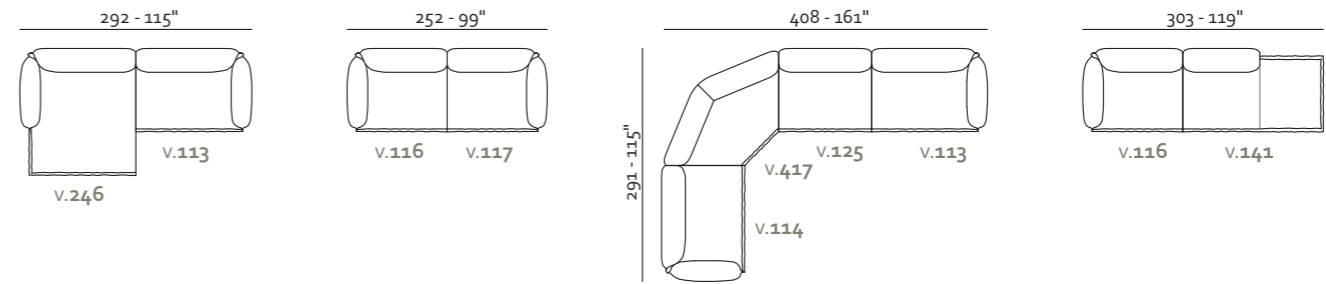

- Rivestimento
Pelle / Tessuto
- Imbottitura
BRACCIOLI / Poliuretano espanso / Piuma
SEDUTA / Poliuretano espanso / Piuma
SPALLIERA / Poliuretano espanso / Piuma
- Comfort Standard
- Piedi Plastica
- Struttura Telaio in legno

- Coverings
Leather / Fabric
- Filling
ARMS / Foam / Feather
SEAT CUSHION / Foam / Feather
BACK CUSHION / Foam / Feather
- Comfort Standard
- Legs Plastic
- Structure Wooden frame

- Revêtement
Cuir / Tissu
- Rembourrage
ACCOUDOIRS / Mousse / Plumes
ASSISE / Mousse / Plumes
DOSSIER / Mousse / Plumes
- Comfort Standard
- Pieds Plastique
- Structure Structure en bois

- Revestimiento
Piel / Tela
- Imbottitura
APOYABRAZOS / Poliuretano expandido / Piuma
SENTADA / Poliuretano expandido / Piuma
RESPALDO / Poliuretano expandido / Piuma
- Comfort Estándar
- Pies Plástico
- Struttura Estructura en madera

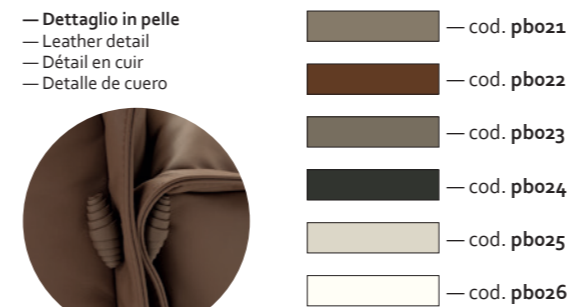

Modello disponibile nelle pelli
Model only available with leathers
Disponible uniquement avec les cuirs
Disponibile solo con pieles

BUTTERFLY
SOAVE
SATIN

mod. **Nido**

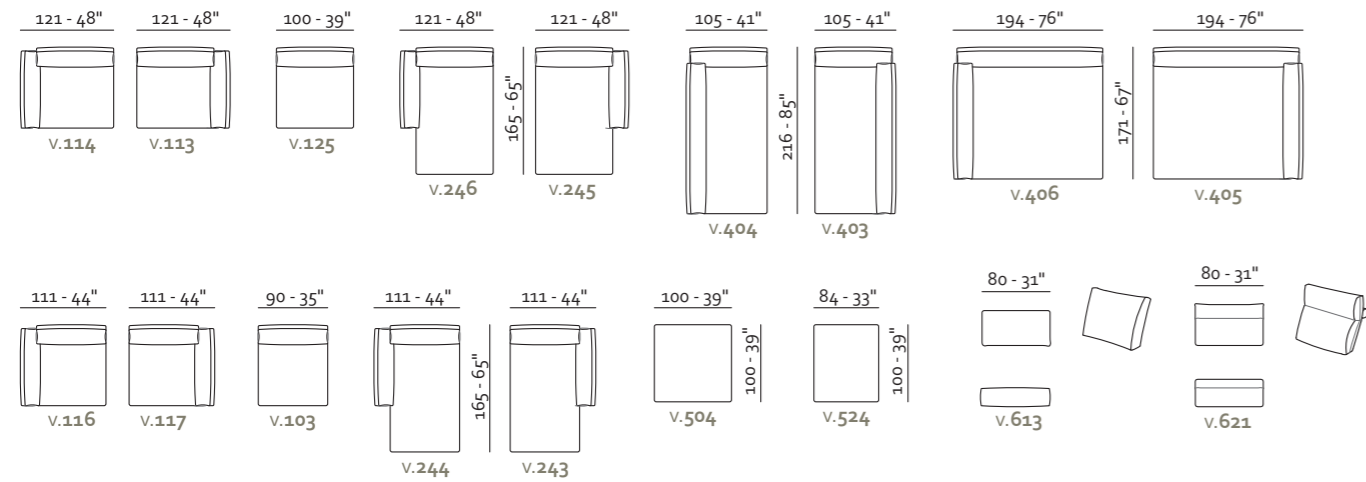

Esempi di componibilità - Sectionals examples - Exemples de compositions - Ejemplos de modularidad

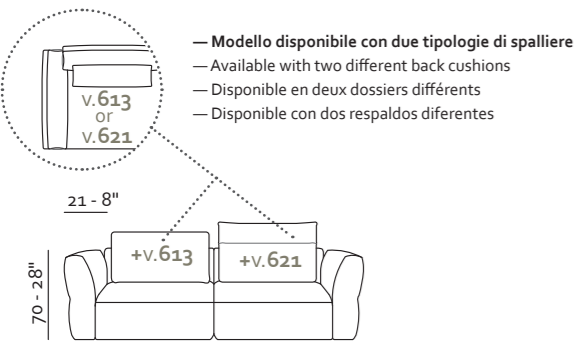
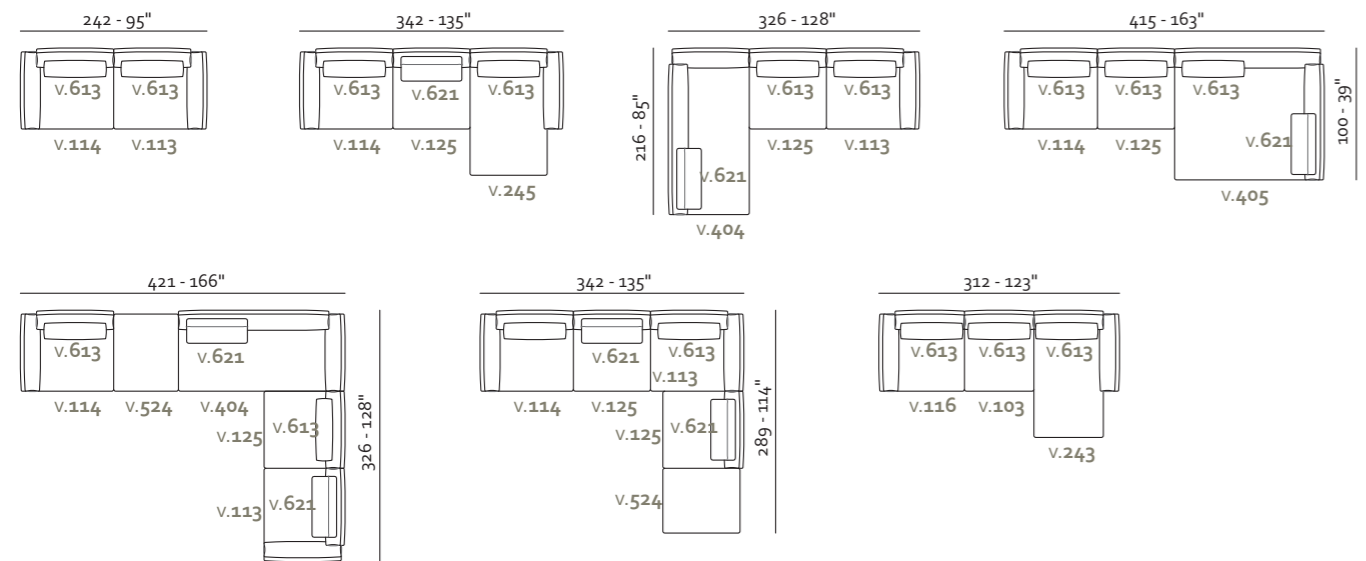

— Modello disponibile con due tipologie di spalliere
 — Available with two different back cushions
 — Disponible en deux dossiers différents
 — Disponible con dos respaldos diferentes



— Dettaglio disponibile in pelle SOAVE
 — Detail only available in Leather SOAVE
 — Détail disponible uniquement en cuir SOAVE
 — Detalle disponible solamente en piel SOAVE

mod. **Sorriso**

patented model

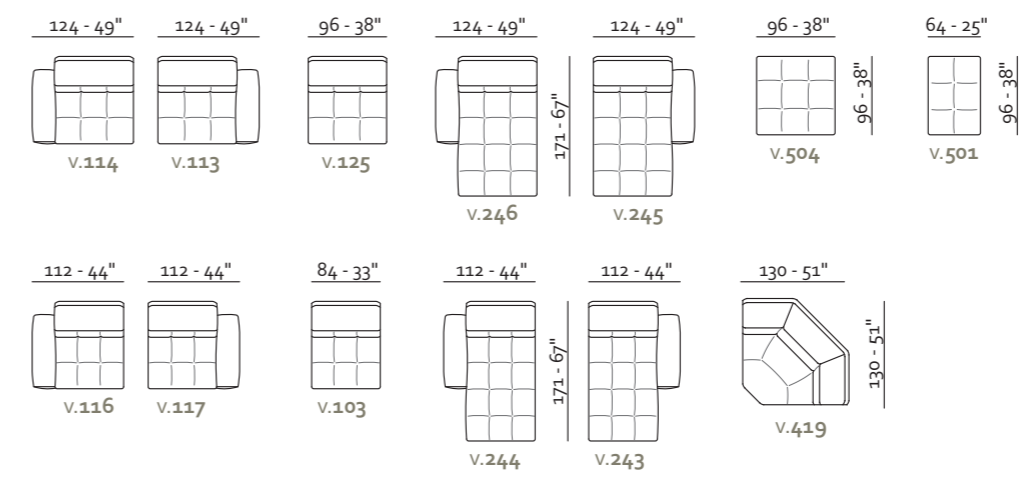
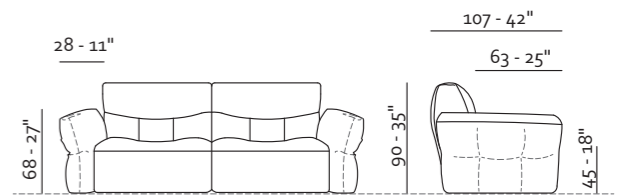

Esempi di componibilità - Sectional examples - Exemples de compositions - Ejemplos de modularidad

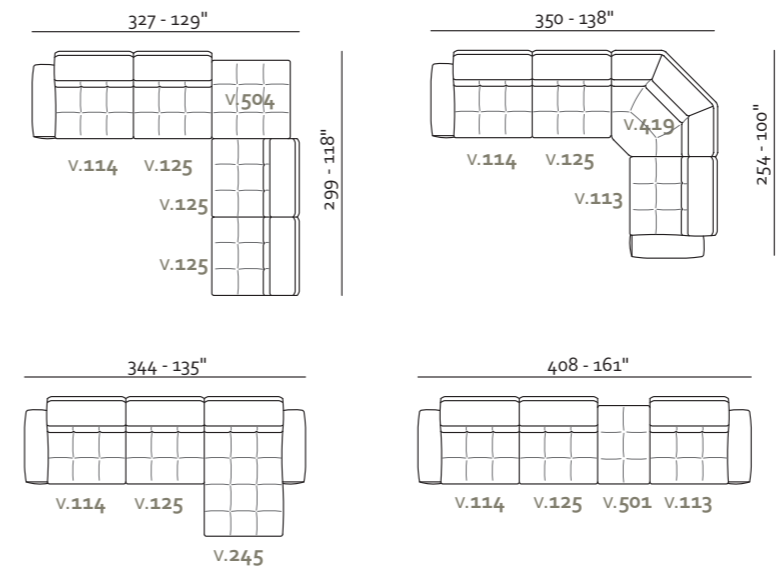

— Rivestimento
 Pelle / Tessuto
 — Imbottitura
 BRACCIOLI / Poliuretano espanso / Piuma
 SEDUTA / Poliuretano espanso / Piuma
 SPALLIERA / Poliuretano espanso / Piuma
 — Comfort Standard
 — Piedi Plastica
 — Struttura Telaio in legno

— Coverings
 Leather / Fabric
 — Filling
 ARMS / Foam / Feather
 SEAT CUSHION / Foam / Feather
 BACK CUSHION / Foam / Feather
 — Comfort Standard
 — Legs Plastic
 — Structure Wooden frame

— Revêtement
 Cuir / Tissu
 — Rembourrage
 ACCOUDOIRS / Mousse / Plumes
 ASSISE / Mousse / Plumes
 DOSSIER / v.613 Plumes
 DOSSIER / v.621 Plumes
 — Comfort Standard
 — Pieds Plastique
 — Structure Structure en bois

— Revestimiento
 Piel / Tela
 — Imbottitura
 APOYABRAZOS / Poliuretano expandido / Piuma
 SENTADA / Poliuretano expandido / Piuma
 RESPALDO / Poliuretano expandido / Piuma
 — Comfort Estándar
 — Pies Plástico
 — Struttura Estructura en madera

— Rivestimento
 Pelle / Tessuto
 — Imbottitura
 BRACCIOLI / Poliuretano espanso
 SEDUTA / Poliuretano espanso
 SPALLIERA / v.613 Piuma
 SPALLIERA / v.621 Piuma
 — Comfort Standard
 — Piedi Plastica
 — Struttura Telaio in legno

— Coverings
 Leather / Fabric
 — Filling
 ARMS / Foam
 SEAT CUSHION / Foam
 BACK CUSHION / v.613 Feather
 BACK CUSHION / v.621 Feather
 — Comfort Standard
 — Legs Plastic
 — Structure Wooden frame

— Revêtement
 Cuir / Tissu
 — Rembourrage
 ACCOUDOIRS / Mousse
 ASSISE / Mousse
 DOSSIER / v.613 Plumes
 DOSSIER / v.621 Plumes
 — Comfort Standard
 — Pieds Plastique
 — Structure Structure en bois

— Revestimiento
 Piel / Tela
 — Imbottitura
 APOYABRAZOS / Poliuretano expandido
 SENTADA / Poliuretano expandido
 RESPALDO / v.613 Piuma
 RESPALDO / v.621 Piuma
 — Comfort Estándar
 — Pies Plástico
 — Struttura Estructura en madera

mod. **Iside**

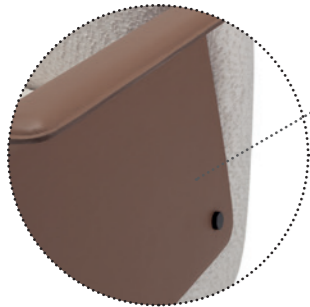
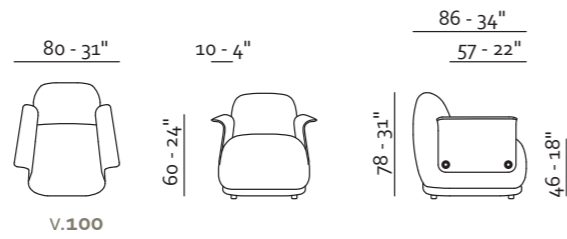
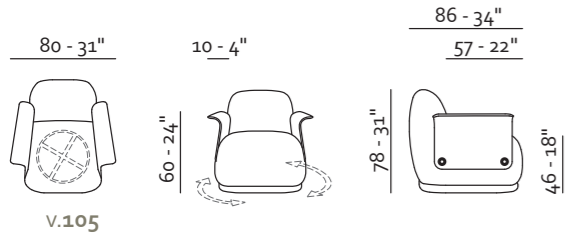

- Dettaglio disponibile in pelle Soave
- Detail only available in Leather Soave
- Détail disponible uniquement en cuir Soave
- Detalle disponible solamente en piel Soave

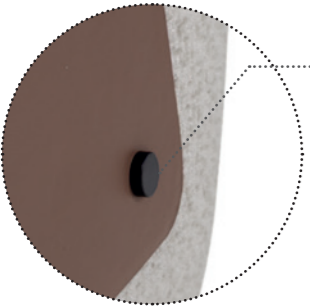

- Finiture
- Finishings
- Finitions
- Acabados

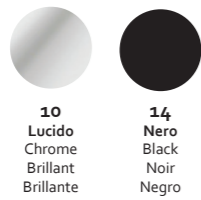

- **Rivestimento**
Tessuto
- **Pelle (solo art. Soave e Mama)**
- **Imbottitura**
BRACCIOLI / Poliuretano espanso
SEDUTA / Poliuretano espanso
SPALLIERA / Poliuretano espanso
- **Comfort Standard**
- **Struttura** Telaio in legno

- **Coverings**
Fabric
- **Leather (only art. Soave e Mama)**
- **Filling**
ARMS / Foam
SEAT CUSHION / Foam
BACK CUSHION / Foam
- **Comfort Standard**
- **Structure** Wooden frame

- **Revêtement**
Tissu
- **Cuir (uniquement de art. Soave e Mama)**
- **Rembourrage**
ACCOUDOIRS / Mousse
ASSISE / Mousse
DOSSIER / Mousse
- **Comfort Standard**
- **Structure** Structure en bois

- **Revestimiento**
Tela
- **Piel (solo art. Soave e Mama)**
- **Imbottitura**
APOYABRAZOS / Poliuretano expandido
SENTADA / Poliuretano expandido
RESPALDO / Poliuretano expandido
- **Comfort Estándar**
- **Struttura** Estructura en madera

mod. **Macaron**

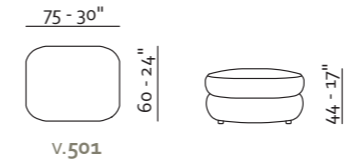
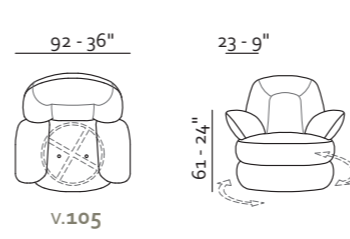

- **Rivestimento**
Pelle / Tessuto
- **Imbottitura**
BRACCIOLI / Poliuretano espanso
SEDUTA / Poliuretano espanso
SPALLIERA / Poliuretano espanso
- **Comfort Standard**
- **Piedi** Plastica
- **Struttura** Telaio in legno

- **Coverings**
Leather / Fabric
- **Filling**
ARMS / Foam
SEAT CUSHION / Foam
BACK CUSHION / Foam
- **Comfort Standard**
- **Legs** Plastic
- **Structure** Wooden frame

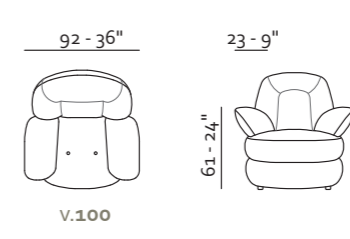

- **Revêtement**
Cuir / Tissu
- **Rembourrage**
ACCOUDOIRS / Mousse
ASSISE / Mousse
DOSSIER / Mousse
- **Comfort Standard**
- **Pieds** Plastique
- **Structure** Structure en bois

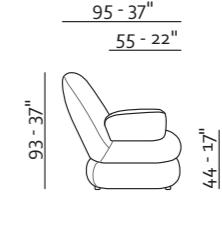

- **Revestimiento**
Piel / Tela
- **Imbottitura**
APOYABRAZOS / Poliuretano expandido
SENTADA / Poliuretano expandido
RESPALDO / Poliuretano expandido
- **Comfort Estándar**
- **Pies** Plástico
- **Struttura** Estructura en madera

mod. **Morea**

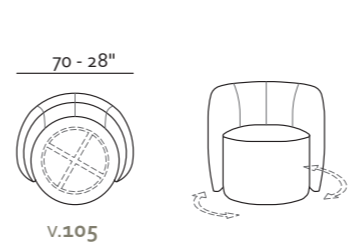

- **Rivestimento**
Pelle / Tessuto
- **Imbottitura**
BRACCIOLI / Poliuretano espanso
SEDUTA / Poliuretano espanso
SPALLIERA / Poliuretano espanso
- **Comfort Standard**
- **Piedi** Plastica
- **Struttura** Telaio in legno

- **Coverings**
Leather / Fabric
- **Filling**
ARMS / Foam
SEAT CUSHION / Foam
BACK CUSHION / Foam
- **Comfort Standard**
- **Legs** Plastic
- **Structure** Wooden frame

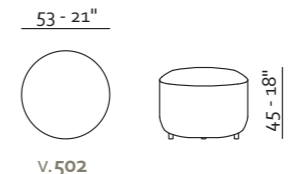

- **Revêtement**
Cuir / Tissu
- **Rembourrage**
ACCOUDOIRS / Mousse
ASSISE / Mousse
DOSSIER / Mousse
- **Comfort Standard**
- **Pieds** Plastique
- **Structure** Structure en bois

- **Revestimiento**
Piel / Tela
- **Imbottitura**
APOYABRAZOS / Poliuretano expandido
SENTADA / Poliuretano expandido
RESPALDO / Poliuretano expandido
- **Comfort Estándar**
- **Pies** Plástico
- **Struttura** Estructura en madera

mod. **Kiko**

patented model

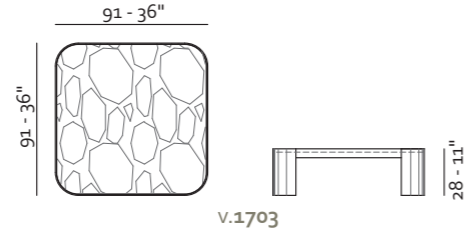
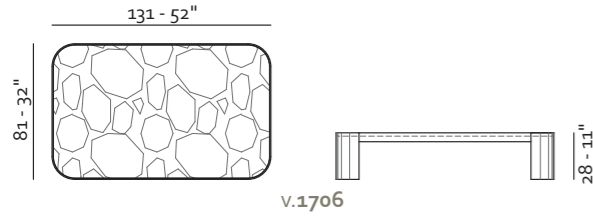

— **Finiture ripiano** - Top finishings - Finitions plateau - Acabados de mesa

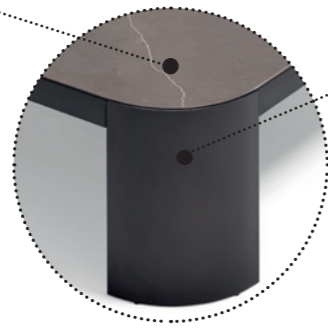
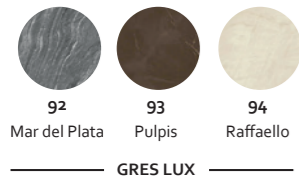

— **Finiture** - Top finishings - Finitions - Acabados

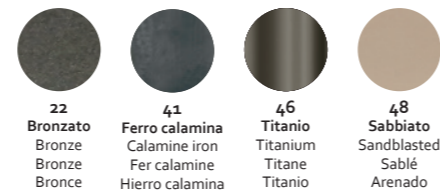

mod. **Luna**

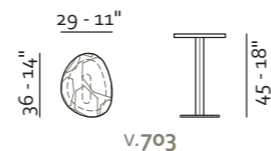
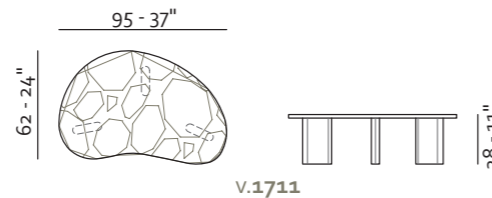
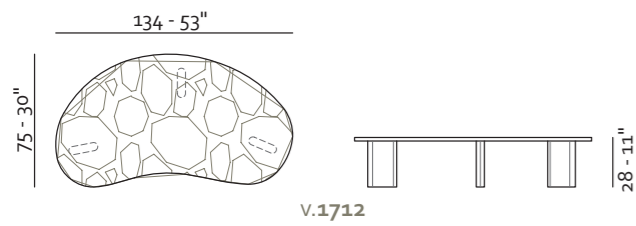

— Rivestimento disponibile in pelle MAMA
 — Detail only available in Leather MAMA
 — Détail disponible uniquement en cuir MAMA
 — Detalle disponible solamente en piel MAMA

— **Finiture ripiano** - Top finishings - Finitions plateau - Acabados de mesa

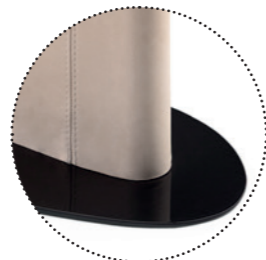
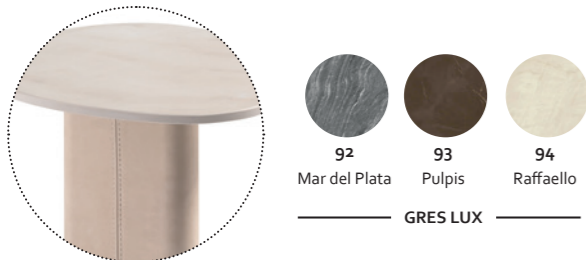

— **Finiture** - Finishings - Finitions - Acabados

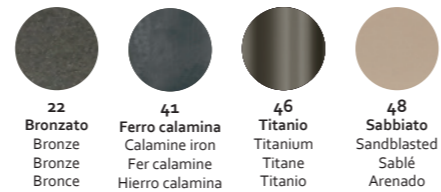

70  maxdivani

 maxdivani

Stampato in Italia - Maggio 2026
Printed in Italy - May 2026

Maxdivani S.r.l. | Largo Epitaffio, 1 | 70022 Altamura (Ba) | Tel. +39 080 926 6200 | info@maxdivani.it | www.maxdivani.it



Maxdivani S.r.l.

Largo Epitaffio, 1
70022 Altamura (BA)
Tel. +39 080 926 6200
info@maxdivani.it

www.maxdivani.it